

## **SFG 100 (Single Fold Glue)**

**Description:** the SFG 100 is a machine that efficiently and rapidly folds over and glues down a previously closed paper bag. The additional fold helps thus to reduce excess free top and gives to the bag a “right-angled parallelepiped” shape, which will allow to stack several bags without any problem and danger on a pallet.

**Process:** the SFG 100 first grasps the bag top as it is exiting the closing equipment, it crimps the bag top, folds it over while applying “hot melt” glue and then compresses the final fold for a secure, attractive seal.

### **Main features:**

- Output of the machine: up to 24,4 m/min
- Capacity to close any width of bag (102mm min)
- Folder
- Width of fold : up to 70mm
- Infeed
- Pneumatic controls
- Creaser with pressure adjustment
- Electrics: 380V, 3ph + N

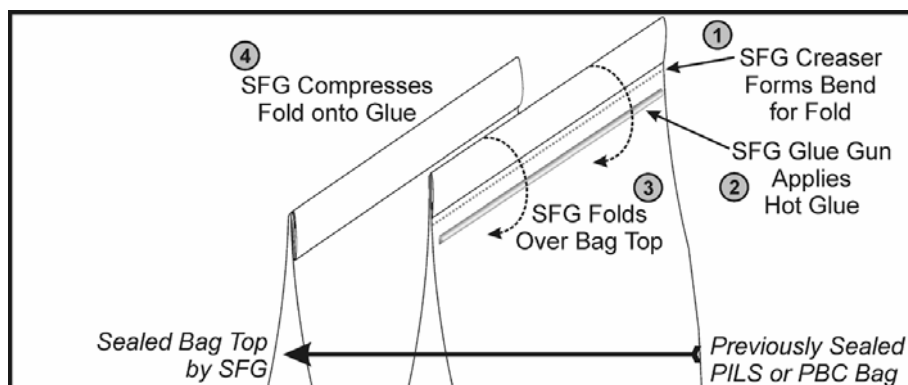

FISCHBEIN S.A.

Paepsem Business Park, Boulevard Paepsem 18b, B-1070 Brussels, Belgium

Tél : +32-2-555.11.70 • Fax : +32-2-520.33.90 • E-Mail : sales@fischbein.be

Website : [www.fischbein.com](http://www.fischbein.com) • TVA/BTW : BE 401.889.806 • RCB/HCB : 264.230

KB Brussels : 432-40142681-31 • BBL Brussels : 310-0825888-19